

INSTALLATION INSTRUCTIONS

VEHICLE	HITCH NO.
HYUNDAI SANTE FE	41543 33037

EQUIPMENT REQUIRED:
 WIRING ACCESS LOCATION: SUV3, SUV4
 DRILL BITS:
 HITCH REQUIRES 5/8" PIN AND CLIP IF STABILIZING PIN IS NOT INSTALLED.
 WRENCHES: (TIGHTEN ALL FASTENERS WITH TORQUE WRENCH) 14mm, 17mm, 19mm

DO NOT EXCEED LOWER OF TOWING VEHICLE MFR'S RATINGS OR

HITCH TYPE ▼	MAX GROSS TRLR WT(LB)	MAX TONGUE WT(LB)
WEIGHT CARRYING	3500	315

DO NOT USE WITH WEIGHT DISTRIBUTING SPRING BAR TYPE HITCH

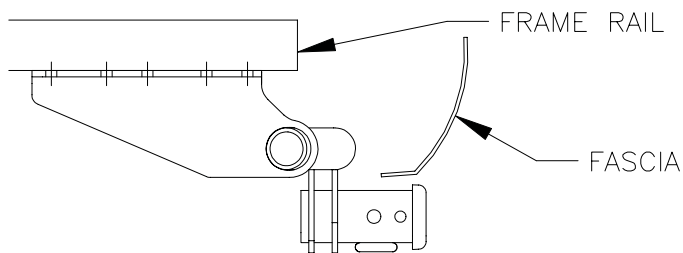

HITCH SHOWN IN PROPER POSITION

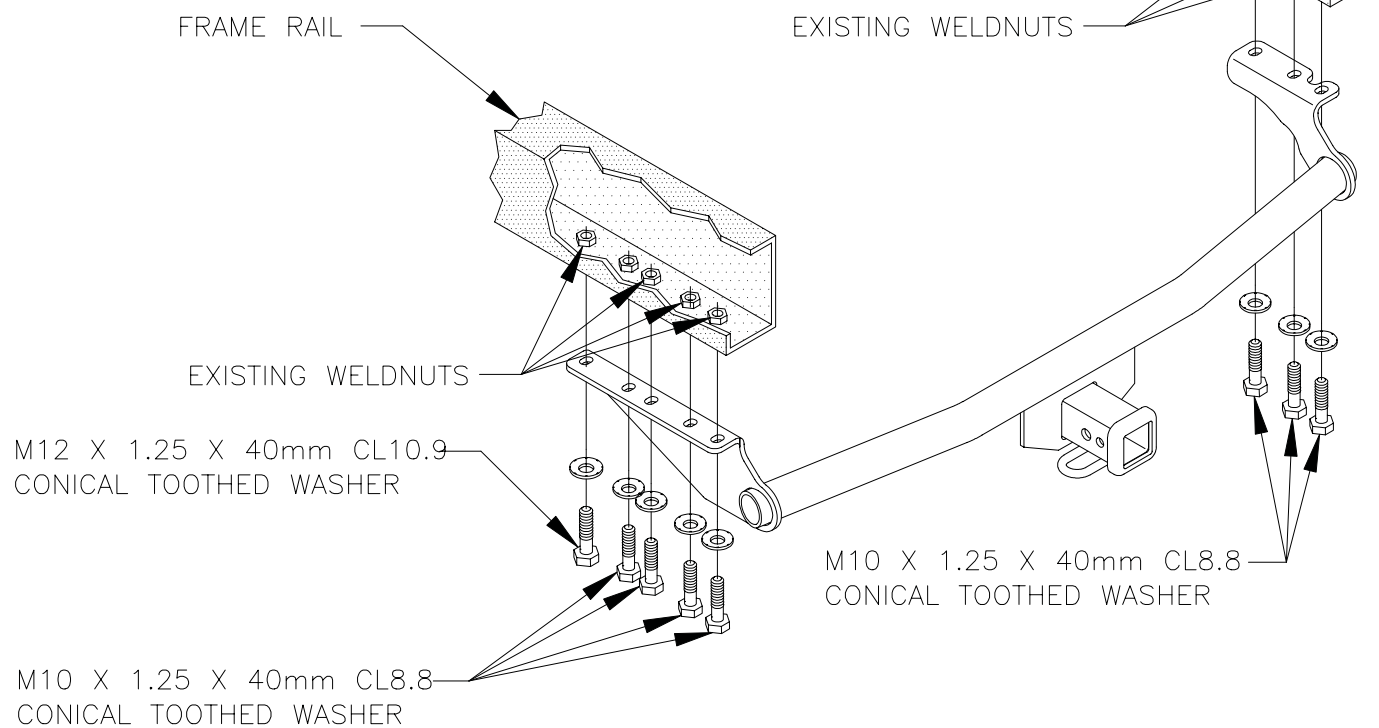

1. REMOVE VEHICLE TIE DOWN BRACKETS AND RETURN WITH FASTENERS TO VEHICLE OWNER.
2. LOWER SPARE TIRE AND VEHICLE EXHAUST.
3. INSTALL FASTENERS AS SHOWN ABOVE.
4. REINSTALL SPARE TIRE AND VEHICLE EXHAUST.

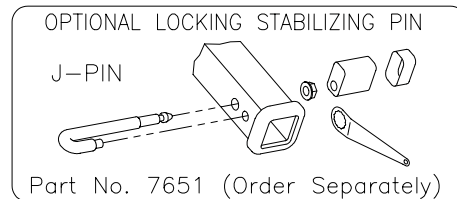

TIGHTEN ALL M10 CL 8.8 FASTENERS TO 38 LB-FT.
 TIGHTEN ALL M12 CL 10.9 FASTENERS TO 68 LB-FT.

THIS PRODUCT COMPLIES WITH SAFETY SPECIFICATIONS AND REQUIREMENTS FOR CONNECTING DEVICES AND TOWING SYSTEMS OF THE STATE OF NEW YORK AND V.E.S.C. REGULATION V-5.

APPROX WEIGHT (LB.)	29	FASTENER KIT NO.	F41543
---------------------	----	------------------	--------

NOTE: Check hitch frequently, making sure all fasteners and ball are properly tightened. If hitch is removed, plug all holes in trunk pan or other body panels to prevent entry of water and exhaust fumes. A hitch or ball which has been damaged should be removed and replaced. Observe safety precautions when working beneath vehicle and wear eye protection. Follow car maker's specs for maximum trailer weight and tongue weight. Do not cut access or attachment holes with a torch.

